

Parcel ID 029-3-025-000

Exterior Information

Table with exterior details: Type (CT - CONTEMPORAR), Stry Hght (2 - Two Sty), (Liv) Units (1), Found (C - CONCRETE), Frame (W - Wood), P. Wall (CL - CLAPBRD.WOOD), Sec Wall (0), Roof Str (GB - GABLE), Roof Cvr (AS - ASPHALT SH), Color, View, Shape, Bld Name.

General Information

Table with general info: Grade (G - GOOD), Year Blt (1993), Eff Yr, Alt LUC, Juris, Con Mod.

Interior Information

Table with interior details: Avg Ht / Fl, P. Int Wall (DW - DRYWALL), Sec Int Wall, Partition, P. Floor (CA - CARPET), Sec Floor (HW - HARDWOOD | 25%), Bmt Floors (C - CONCRETE BMT), Sub Floors, Bmt Garage (0), Electric (T - TYPICAL), Insulation (T - TYPICAL), Int Vs Ext, Heat Fuel (G - GAS), Heat (HW - HOT WATER), # Heat Sys (1), Heated %, AC %, Sol HW %, Ctrl Vac %, Com Wall %, Sprink %.

Special Features / Yard Items

Table for special features and yard items with columns: Code, Desc, A, Y/S, Qty, Size, Qual, Con, Year, Unit Prc, D/S, Depr %, LUC, Ft, NBC, Ft, Juris, Ft, Appr Val, Assessed.

Disclaimer: This Information is believed to be correct but is subject to change and is not quarante

Condo Information

Table with condo details: Location, Tot Units, Floor, % Own, Name.

Bath Features

Table with bath features: Full Bath (3), Add Full (0), 3/4 Bath (0), Add. 3/4 (0), 1/2 Bath (1), Add. 1/2 (0), Other Fix (2).

Other Features

Table with other features: Kitchens (1), Add Kit. (0), Fireplaces (1), WS Flues (0).

Depreciation

Table with depreciation: Phys Con (AG), Functional, Economic, Special, Override, Total (15.29%).

Comparable Sales (7 of 15)

Table with comparable sales: Rtnng, Parcel ID, Type, Sale Date, Price, Avg Rtnng (69.47), Ind Val (11,316,597).

Comments

OVER 2ACRES .616 INCREMENTAL

Res Breakdown

Table with res breakdown: Floor, No. Unit, Rooms, Bdrms, Bld Total (1, 7, 3), Prcl Total (1, 7, 3).

Calc Ladder

Table with calc ladder: Base Rate (65.00), Depr (86,667), Size Adj (0.97530), Depr'd Total (480,155), Con Adj (1.00250), Juris Ft. (1.0000), Adj Prc (\$63.55), Spec. Features (\$0), Grade Ft. (1.23000), Lump Sum, Other Feat (\$24,600), Final Total (\$480,200), NBH Mod (1.0000), Override Val, NBC Infl (1.9200), Assmnt Ft. (1.0000), LUC Ft. (1.0000), Assessed Val (\$480,200), Adj Tot (RCN) (566,822), Total \$/SF (\$160.52), Depr % (15.29%), Undepr \$/SF (78.16650).

Sub Areas (7 of 9)

Table with sub areas: Code, Desc, Net Area, Gross A., F. Area, Sz Adj A., Rate AV, Undepr Val, Building Totals, Parcel Totals.

Sketch

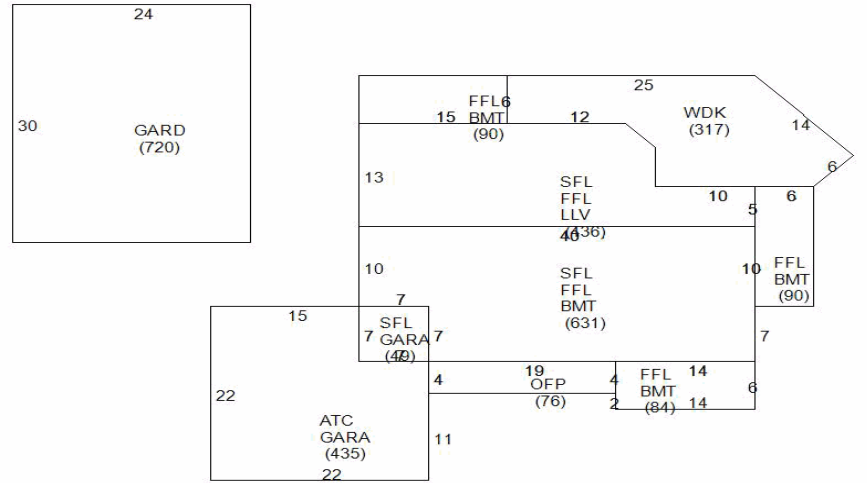

Mobile Home

Table for mobile home details: Make, Model, Serial, Year, Color.

Alt Areas

Table with alt areas: S. Area, Alt Type, % Alt, Tenants, Qual, % U.

Image

