

033 4 019 000
Sheet Lot Unit# Bldg#

033-4-019-000
Parcel ID Building Location 52 INSTITUTE RD

BURLINGTON, VT

Card: 1 of 7 Total Card Total Parcel

PROPERTY LOCATION

52 INSTITUTE RD
BURLINGTON, VT 05401

OWNERSHIP

CITY SCHOOL DEPARTMENT
ADMISTRATIVE OFFICES/EED
150 COLCHESTER AV
BURLINGTON, VT 05401-0000

PREVIOUS OWNER

Occ C Type CITY

NARRATIVE DESCRIPTION

This parcel contains 1412709.00000 SF of land mainly classified as Exempt It has 7 building(s) first built in 1968 with a total of 108,640 square feet. There are 7 commercial unit(s), 11 Baths, 29 Half Baths.

OTHER ASSESSMENTS

Table with columns: Code, Desc, Amt, Comm Int Amt

PROPERTY FACTORS

Table with columns: Item, Code, Item, Code, %

LAND SECTION

Table with columns: LUC, LUC Desc, Ft, # Units, Depth, U. Type, L. Type, Ft, Base V, Unit Prc, Adj Prc, NBC, Ft, Mod, Inf 1, %, Inf 2, %, Inf 3, %, Apor, Alt LUC, %, Spec I. V, Juris, L. Ft, Assessed, Notes

IN PROCESS APPRAISAL SUMMARY

Table with columns: Use Code, Building Val, Yard Items, Land Size, Land Val, Total Val

PREVIOUS ASSESSMENTS

Table with columns: Tx Yr, Cat, Use, Bld Value, Yard Items, Land Size, Land Val, Total Aoor, Assessed, Notes, Date

SALES INFORMATION

Table with columns: Grantor, Legal Ref, Type, Date, Sale Price, TSF, Verif, NAL, Notes

BUILDING PERMITS

Table with columns: Date, Number, Desc, Amount, Closed, Status, Fed. ID, Notes, Last Visit

ACTIVITIES

Table with columns: Date, Result, Bv

LEGAL DESCRIPTION

Table with columns: Lot Size, Total Land, Land Unit Type

Property ID: 3542



User Account table with fields: User Account, 13542, GIS Coord 1, 308543728872.00000000, GIS Coord 1, Insp Date, Print Date / Time, 7/24/2024 1:30 am, Last Date / Time, 6/14/23 3:49 pm, BURLINGTON\jturner

USER DEFINED

Table with fields: RAD, OLD PID: 4444SCHOOL, State District, CAD, SPAN: 114-035-13542, Accessory Dwl, PriorID1c, 00, PriorID2c, 00, PriorID3c, 00, Assessor Map

033 Sheet 4 Lot 019 Unit# 000 Bldg#

033-4-019-000 Parcel ID Building Location 52 INSTITUTE RD

BURLINGTON, VT

Card: 2 of 7 Total Card 3,580,900 / Total Parcel 34,844,200
APPR 3,580,900 / 34,844,200
USE + IMP 3,580,900 / 34,844,200
USE LAND 3,580,900 / 34,844,200
ASSESSED 3,580,900 / 34,844,200

PROPERTY LOCATION

52 INSTITUTE RD
BURLINGTON, VT 05401

OWNERSHIP

CITY SCHOOL DEPARTMENT
ADMISTRATIVE OFFICES/EED
150 COLCHESTER AV
BURLINGTON, VT 05401-0000

Occ C Type CITY

PREVIOUS OWNER

NARRATIVE DESCRIPTION

This parcel contains 1412709.00000 SF of land mainly classified as Exempt It has 7 building(s) first built in 1968 with a total of 23,500 square feet. There are 7commercial unit(s), 11 Baths, 29 Half Baths.

OTHER ASSESSMENTS

Table with columns: Code, Desc, Amt, Comm Int Amt

PROPERTY FACTORS

Table with columns: Item, Code, Item, Code, %

LAND SECTION

Table with columns: LUC, LUC.Desc, Ft, # Units, Depth, U_Type, L_Type, Ft, Base V, Unit Prc, Adi Prc, NBC, Ft, Mod, Inf 1, %, Inf 2, %, Inf 3, %, Apor, Alt LUC, %, Spec I.V, Juris, L.Ft, Assessed, Notes

IN PROCESS APPRAISAL SUMMARY

Table with columns: Use Code, Building Val, Yard Items, Land Size, Land Val, Total Val

PREVIOUS ASSESSMENTS

Table with columns: Tx Yr, Cat, Use, Bld Value, Yard Items, Land Size, Land Val, Total Apor, Assessed, Notes, Date

SALES INFORMATION

Table with columns: Grantor, Legal Ref, Type, Date, Sale Price, TSF, Verif, NAL, Notes

BUILDING PERMITS

Table with columns: Date, Number, Desc, Amount, Closed, Status, Fed. ID, Notes, Last Visit

ACTIVITIES

Table with columns: Date, Result, Bv

LEGAL DESCRIPTION

Table with columns: Lot Size, Total Land, Land Unit Type

Property ID: 3542



User Account table with fields: User Account, 13542, GIS Coord 1, 308543728872.00000000, GIS Coord 1, Insp Date, Print Date / Time, 7/24/2024 1:30 am, Last Date / Time, 6/14/23 3:49 pm, BURLINGTONjturner

USER DEFINED

Table with fields: RAD, OLD PID: 4444SCHOOL, State District, CAD, SPAN: 114-035-13542, Accessory Dwl, PriorID1c 00, PriorID2c 00, PriorID3c 00, Assessor Map

Parcel ID 033-4-019-000

Exterior Information

Table with exterior details: Type (363 - SCHOOLS ELEM), Stry Hght (2 - Two Sty), (Liv) Units (0), Found (S - SLAB), Frame (C - FireResistAV), P. Wall (BV - BRICK VENEER), Sec Wall (0), Roof Str (FL - FLAT), Roof Cvr (RM - RUBBER MEMB), Color, View (AV - AVERAGE), Shape, Bld Name.

General Information

Table with general details: Grade (A+ - AVERAGE PLUS), Year Blt (1968), Eff Yr, Alt LUC, Juris, Con Mod.

Interior Information

Table with interior details: Avg Ht / Ft (10.00), P. Int Wall (DW - DRYWALL), Sec Int Wall (CB - CON BLOCK 40%), Partition, P. Floor (V - VINYL), Sec Floor (CA - CARPET 25%), Bmt Floors, Sub Floors, Bmt Garage (0), Electric (T - TYPICAL), Insulation (T - TYPICAL), Int Vs Ext, Heat Fuel (G - GAS), Heat (HW - HOT WATER), # Heat Sys (2), Heated % (100), Sol HW %, Com Wall %, Sprink %.

Special Features / Yard Items

Table with special features and yard items: Columns include Code, Desc, A, Y/S, Qty, Size, Qual, Con, Year, Unit Prc, D/S, Depr %, LUC, Ft, NBC, Ft, Juris, Ft, Appr Val, Assessed. Includes Building and Parcel Totals for Yard Item Appr and Special Feature Appr.

Disclaimer: This Information is believed to be correct but is subject to change and is not quarante

Condo Information

Table with condo details: Location, Tot Units, Floor, % Own, Name.

Bath Features

Table with bath features: Full Bath, Add Full, 3/4 Bath, Add. 3/4, 1/2 Bath, Add. 1/2, Other Fix, with Rtnq values.

Other Features

Table with other features: Kitchens, Add Kit., Fireplaces, WS Flues, with Rtnq values.

Depreciation

Table with depreciation: Phys Con (AV), Functional, Economic, Special, Override, Total 30%.

Comparable Sales

Table with comparable sales: Columns include Rtnq, Parcel ID, Type, Sale Date, Price, Avg Rtnq, Ind Val.

Comments

BURLINGTON HIGH SCHOOL
B BUILDING

Res Breakdown

Table with res breakdown: Columns include Floor, No. Unit, Rooms, Bdrms, Bld Total, Prcl Total.

Calc Ladder

Table with calc ladder: Base Rate (104.60), Size Adj (1.00000), Con Adj (1.11663), Adj Prc (\$116.80), Grade Ft (1.07000), Other Feat (\$24,610), NBH Mod (1.0000), NBC Infl (1.6700), LUC Ft (1.0000), Adj Tot (5,069,313), Depr % (30%), Total \$/SF (151.00), Undepr \$/SF (124.97600).

Sub Areas

Table with sub areas: Columns include Code, Desc, Net Area, Gross A., F. Area, Sz Adj A., Rate AV, Undepr Val, Building Totals, Parcel Totals.

Sketch

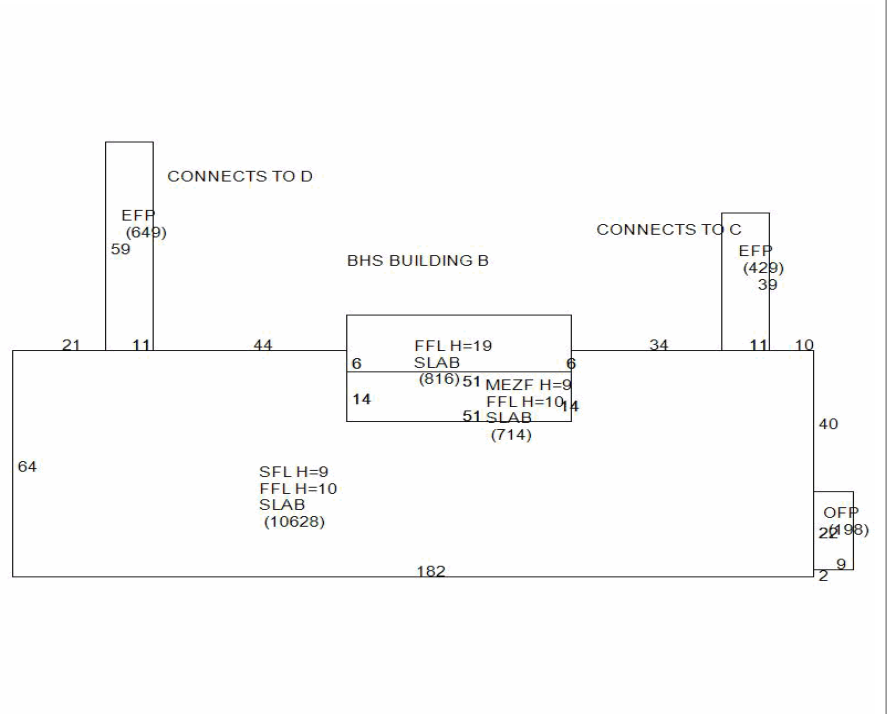

Mobile Home

Table with mobile home details: Make, Model, Serial, Year, Color.

Alt Areas

Table with alt areas: Columns include S. Area, Alt Type, % Alt, Tenants, Qual, % U.

Image



033 Sheet 4 Lot 019 Unit# 000 Bldg#

033-4-019-000 Parcel ID Building Location 52 INSTITUTE RD

BURLINGTON, VT

Card: 3 of 7 Total Card 3,185,100 / Total Parcel 34,844,200
APPR 3,185,100 / 34,844,200
USE + IMP 3,185,100 / 34,844,200
USE LAND 3,185,100 / 34,844,200
ASSESSED 3,185,100 / 34,844,200

PROPERTY LOCATION
52 INSTITUTE RD
BURLINGTON, VT 05401

IN PROCESS APPRAISAL SUMMARY

Table with columns: Use Code, Building Val, Yard Items, Land Size, Land Val, Total Val. Rows include E, Building Total, Parcel Total, Source.

LEGAL DESCRIPTION

Table with columns: Lot Size, Total Land, Land Unit Type. Values: Lot Size, 1,412,709.00, SF.

OWNERSHIP
CITY SCHOOL DEPARTMENT
ADMISTRATIVE OFFICES/EED
150 COLCHESTER AV
BURLINGTON, VT 05401-0000

PREVIOUS ASSESSMENTS

Table with columns: Tx Yr, Cat, Use, Bld Value, Yard Items, Land Size, Land Val, Total Aoor, Assessed, Notes, Date. Rows from 2019 to 2024.

Property ID: 3542

PREVIOUS OWNER
Occ C Type CITY

NARRATIVE DESCRIPTION
This parcel contains 1412709.00000 SF of land mainly classified as Exempt It has 7 building(s) first built in 1968 with a total of 22,378 square feet. There are 7commercial unit(s), 11 Baths, 29 Half Baths.

SALES INFORMATION

Table with columns: Grantor, Legal Ref, Type, Date, Sale Price, TSF, Verif., NAL, Notes.

OTHER ASSESSMENTS
Code Desc Amt Comm Int Amt

BUILDING PERMITS

Table with columns: Date, Number, Desc, Amount, Closed, Status, Fed. ID, Notes, Last Visit.

ACTIVITIES

Table with columns: Date, Result, Bv.

PROPERTY FACTORS
Item Code Item Code %
Util 1 Dis 1 B .00000
Util 2 Dis 2 SN .00000
Util 3 Dis 3
Census Zone 1
F. Haz Zone 2
Tono Zone 3
Street
Traffic
Exempt

LAND SECTION
Table with columns: LUC, LUC Desc, Ft, # Units, Depth, U. Type, L. Type, Ft, Base V, Unit Prc, Adi Prc, NBC, Ft, Mod, Inf 1, %, Inf 2, %, Inf 3, %, Aoor, Alt LUC, %, Spec I. V., Juris, L. Ft., Assessed, Notes.



User Account
13542
GIS Coord 1
308543728872.00000000
GIS Coord 1
Insp Date
Print Date / Time
7/24/2024 1:30 am
Last Date / Time
6/14/23 3:49 pm
BURLINGTONjturner

USER DEFINED
RAD:
OLD PID:
4444SCHOOL
State District:
CAD:
SPAN:
114-035-13542
Accessory Dwl
PriorID1c
00
PriorID2c
00
PriorID3c
00
Assessor Map

Parcel ID 033-4-019-000

Exterior Information

Table with exterior details: Type (363 - SCHOOLS ELEM), Stry Hght (2 - Two Sty), (Liv) Units (0), Found (S - SLAB), Frame (C - FireResistAV), P. Wall (BV - BRICK VENEER), Sec Wall (0), Roof Str (FL - FLAT), Roof Cvr (RM - RUBBER MEMB), Color, View (AV - AVERAGE), Shape, Bld Name.

General Information

Table with general details: Grade (A+ - AVERAGE PLUS), Year Blt (1968), Eff Yr, Alt LUC, Juris, Con Mod.

Interior Information

Table with interior details: Avg Ht / Ft (9.00), P. Int Wall (DW - DRYWALL), Sec Int Wall (CB - CON BLOCK 40%), Partition, P. Floor (V - VINYL), Sec Floor, Bmt Floors, Sub Floors, Bmt Garage (0), Electric (T - TYPICAL), Insulation (T - TYPICAL), Int Vs Ext, Heat Fuel (G - GAS), Heat (HW - HOT WATER), # Heat Sys (2), Heated % (100), AC %, Sol HW %, Ctrl Vac %, Com Wall %, Sprink %.

Special Features / Yard Items

Table for special features and yard items with columns: Code, Desc, A, Y/S, Qty, Size, Qual, Con, Year, Unit Prc, D/S, Depr %, LUC, Ft, NBC, Ft, Juris, Ft, Appr Val, Assessed.

Disclaimer: This Information is believed to be correct but is subject to change and is not guarante

Condo Information

Table with condo details: Location, Tot Units, Floor, % Own, Name.

Bath Features

Table with bath features: Full Bath (0), Add Full (0), 3/4 Bath (0), Add. 3/4 (0), 1/2 Bath (4), Add. 1/2 (0), Other Fix (20).

Other Features

Table with other features: Kitchens (0), Add Kit. (0), Fireplaces (0), WS Flues (0).

Depreciation

Table with depreciation details: Phys Con (AV), Functional, Economic, Special, Override, Total (30%).

Comparable Sales

Table for comparable sales with columns: Rtnq, Parcel ID, Type, Sale Date, Price, Avg Rtnq, Ind Val.

Comments

BURLINGTON HIGH SCHOOL
C BUILDING

Res Breakdown

Table with res breakdown: Floor, No. Unit, Rooms, Bdrms, Bld Total, Prcl Total.

Calc Ladder

Table with calc ladder: Base Rate (104.60), Size Adj (1.00000), Con Adj (1.10237), Adj Prc (\$115.31), Grade Ft. (1.07000), Other Feat (\$29,960), NBH Mod (1.0000), NBC Infl (1.6700), LUC Ft. (1.0000), Adj Tot (4,550,201), Depr % (30%), Depr (1,365,060), Depr'd Total (3,185,141), Juris Ft. (1.0000), Spec. Features (\$0), Lump Sum, Final Total (\$3,185,100), Override Val (1.0000), Assmnt Ft. (1.0000), Assessed Val (\$3,185,100), Total \$/SF (\$142.33), Undepr \$/SF (123.38170).

Sub Areas

Table with sub areas: Code, Desc, Net Area, Gross A., F. Area, Sz Adj A., Rate AV, Undepr Val, Building Totals, Parcel Totals.

Sketch

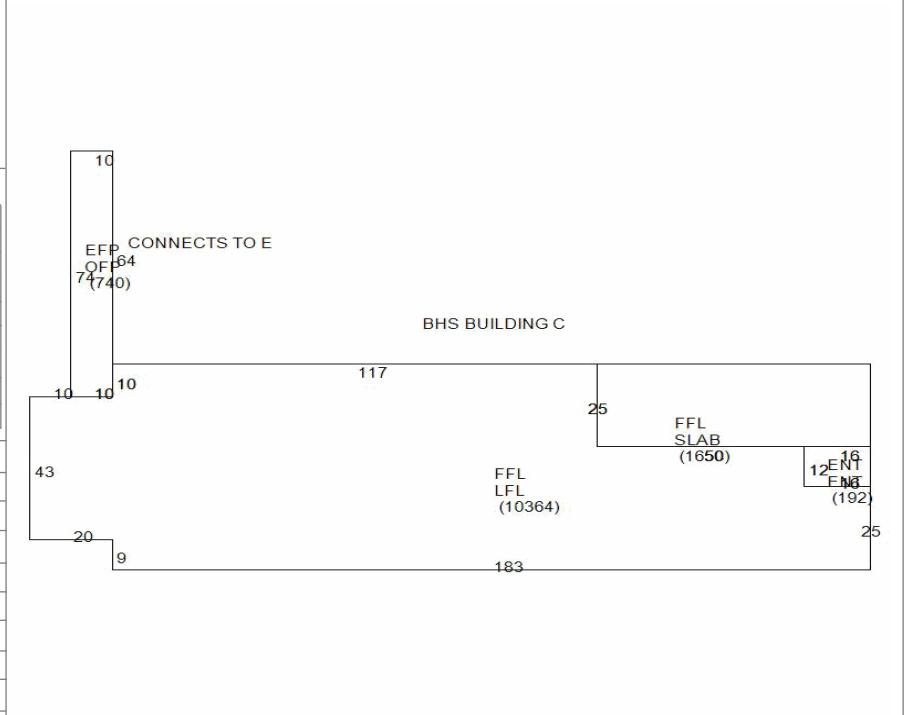

Mobile Home

Table for mobile home details: Make, Model, Serial, Year, Color.

Alt Areas

Table for alternative areas with columns: S. Area, Alt Type, % Alt, Tenants, Qual, % U.

Image



Property: 3542 | Bld: 3615 | Seq: 3 | Year: | Data As Of Date: 07/01/2024 | User: sa | DB: Assess50Burlington

033 Sheet 4 Lot 019 Unit# 000 Bldg#

033-4-019-000 Parcel ID Building Location 52 INSTITUTE RD

BURLINGTON, VT

Card: 4 of 7 Total Card 2,552,600 / 34,844,200
 APPR 2,552,600 / 34,844,200
 USE + IMP 2,552,600 / 34,844,200
 USE LAND 2,552,600 / 34,844,200
 ASSESSED 2,552,600 / 34,844,200

PROPERTY LOCATION
 52 INSTITUTE RD
 BURLINGTON, VT 05401

IN PROCESS APPRAISAL SUMMARY

Use Code	Building Val	Yard Items	Land Size	Land Val	Total Val
E	2,552,600	0	0.00	0	2,552,600
Building Total	2,552,600	0	0.00	0	2,552,600
Parcel Total	34,314,300	178,900	1,412,709.00	351,000	34,844,200
Source	0 - Mkt Adj Cost	Tot Val SF/Bld	157.84	Tot Val SF/Prcf	149.83

LEGAL DESCRIPTION

Lot Size	
Total Land	1,412,709.00
Land Unit Type	SF

OWNERSHIP
 CITY SCHOOL DEPARTMENT
 ADMISTRATIVE OFFICES/EED
 150 COLCHESTER AV
 BURLINGTON, VT 05401-0000

PREVIOUS ASSESSMENTS

Property ID: 3542

Tx Yr	Cat	Use	Bld Value	Yard Items	Land Size	Land Val	Total Aoor	Assessed	Notes	Date
2024	FV	E	34,314,300	178,900	1,412,709	351,000	34,844,200	34,844,200	2024/LDS 06/14/24 11:54:51	06/14/2024
2023	FV	E	34,314,300	178,900	1,412,709	351,000	34,844,200	34,844,200	2023/LDS 07/07/23 9:47:36	07/07/2023
2022	FV	E	34,314,300	178,900	1,412,709	351,000	34,844,200	34,844,200	2022/LDS 08/25/22 10:15:25	08/25/2022
2021	FV	E	34,314,300	178,900	1,412,709	351,000	34,844,200	34,844,200	DS Patriot Support	01/11/2022
2020	FV	E	26,703,500	167,100	1,412,709	5,556,400	32,427,000	32,427,000	post BOA	06/23/2020
2019	FV	E	26,703,500	167,100	1,412,709	5,556,400	32,427,000	32,427,000	9.23.2019	09/23/2019

PREVIOUS OWNER

Occ	C	Type	CITY
-----	---	------	------

NARRATIVE DESCRIPTION
 This parcel contains 1412709.00000 SF of land mainly classified as Exempt It has 7 building(s) first built in 1968 with a total of 16,172 square feet. There are 7commercial unit(s), 11 Baths, 29 Half Baths.

SALES INFORMATION

Grantor	Legal Ref	Type	Date	Sale Price	TSF	Verif.	NAL	Notes

OTHER ASSESSMENTS

Code	Desc	Amt	Comm Int Amt

PROPERTY FACTORS

Item Code	Item	Code	%
Util 1	Dis 1	B	.00000
Util 2	Dis 2	SN	.00000
Util 3	Dis 3		
Census	Zone 1		
F. Haz	Zone 2		
Tono	Zone 3		
Street			
Traffic			
Exempt			

BUILDING PERMITS

Date	Number	Desc	Amount	Closed	Status	Fed. ID	Notes	Last Visit

ACTIVITIES

Date	Result	Bv

LAND SECTION

LUC	LUC Desc	Ft.	# Units	Depth	U. Type	L. Type	Ft.	Base V.	Unit Prc	Adi Prc	NBC	Ft.	Mod.	Inf 1	%	Inf 2	%	Inf 3	%	Aoor	Alt LUC	%	Spec I. V.	Juris	L. Ft.	Assessed	Notes
E	Exempt	1	1,412,709		SF	SITE	1	39	0.25	610	1			Z						351,000			0		1	351,000	
E	Exempt	1	0		SF	SITE	1	39	0	610	1									0			0		1	0	
E	Exempt	1	0		SF	SITE	1	39	0	610	1									0			0		1	0	
E	Exempt	1	0		SF	SITE	1	39	0	610	1									0			0		1	0	
E	Exempt	1	0		SF	SITE	1	39	0	610	1									0			0		1	0	
E	Exempt	1	0		SF	SITE	1	39	0	610	1									0			0		1	0	
Total AC/HA		32.43		Total SF/SM		1,412,709.00		Parcel LUC E - Exempt			P. NBC Desc		NEW NO END		Tot		351,000		Tot		0		Tot		351,000		



User Account

13542
GIS Coord 1
308543728872.00000000
GIS Coord 1
Insp Date
Print Date / Time
7/24/2024 1:30 am
Last Date / Time
6/14/23 3:49 pm
BURLINGTONjturner

USER DEFINED

RAD:

OLD PID:

4444SCHOOL

State District:

CAD:

SPAN:

114-035-13542

Accessory Dwl

PriorID1c

00

PriorID2c

00

PriorID3c

00

Assessor Map

Parcel ID 033-4-019-000

Exterior Information

Table with exterior details: Type (363 - SCHOOLS ELEM), Stry Hght (2 - Two Sty), (Liv) Units (0), Found (S - SLAB), Frame (C - FireResistAV), P. Wall (BV - BRICK VENEER), Sec Wall (0), Roof Str (FL - FLAT), Roof Cvr (RM - RUBBER MEMB), Color, View (AV - AVERAGE), Shape, Bld Name.

General Information

Table with general details: Grade (A+ - AVERAGE PLUS), Year Blt (1970), Eff Yr, Alt LUC, Juris, Con Mod.

Interior Information

Table with interior details: Avg Ht / Fl (9.00), P. Int Wall (DW - DRYWALL), Sec Int Wall (CB - CON BLOCK 40%), Partition, P. Floor (V - VINYL), Sec Floor, Bmt Floors, Sub Floors, Bmt Garage (0), Electric (T - TYPICAL), Insulation (T - TYPICAL), Int Vs Ext, Heat Fuel (G - GAS), Heat (HW - HOT WATER), # Heat Sys (2), Heated % (100), AC %, Sol HW %, Ctrl Vac %, Com Wall %, Sprink %.

Special Features / Yard Items

Table for special features and yard items with columns: Code, Desc, A, Y/S, Qty, Size, Qual, Con, Year, Unit Prc, D/S, Depr %, LUC, Ft, NBC, Ft, Juris, Ft, Appr Val, Assessed.

Condo Information

Table with condo details: Location, Tot Units, Floor, % Own, Name.

Bath Features

Table with bath features: Full Bath (0), Add Full (0), 3/4 Bath (0), Add. 3/4 (0), 1/2 Bath (3), Add. 1/2 (0), Other Fix (12), Rtnq.

Other Features

Table with other features: Kitchens (0), Add Kit. (0), Fireplaces (0), WS Flues (0), Rtnq.

Depreciation

Table with depreciation details: Phys Con (AV), Functional, Economic, Special, Override, Total (30%).

Comparable Sales

Table for comparable sales with columns: Rtnq, Parcel ID, Type, Sale Date, Price, Avg Rtnq, Ind Val.

Comments

BURLINGTON HIGH SCHOOL
D BUILDING

Res Breakdown

Table with res breakdown: Floor, No. Unit, Rooms, Bdrms, Bld Total, Prcl Total.

Calc Ladder

Table with calculation ladder: Base Rate (104.60), Size Adj (1.00000), Con Adj (1.10237), Adj Prc (\$115.31), Grade Ft. (1.07000), Other Feat (\$19,260), NBH Mod (1.0000), NBC Infl (1.6700), LUC Ft. (1.0000), Adj Tot (3,646,627), Depr % (30%), Depr (1,093,988), Depr'd Total (2,552,639), Juris Ft. (1.0000), Spec. Features (\$0), Lump Sum, Final Total (\$2,552,600), Override Val (1.0000), Assmnt Ft. (1.0000), Assessed Val (\$2,552,600), Total \$/SF (\$157.84), Undepr \$/SF (123.38170).

Sub Areas

Table with sub areas: Code, Desc, Net Area, Gross A., F. Area, Sz Adj A., Rate AV, Undepr Val, Building Totals, Parcel Totals.

Sketch

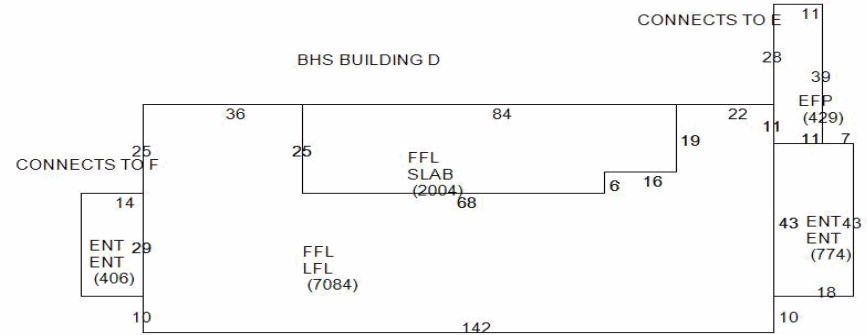

Mobile Home

Table for mobile home details: Make, Model, Serial, Year, Color.

Alt Areas

Table for alternative areas with columns: S. Area, Alt Type, % Alt, Tenants, Qual, % U.

Image



033 4 019 000
Sheet Lot Unit# Bldg#

033-4-019-000
Parcel ID Building Location 52 INSTITUTE RD

BURLINGTON, VT

Card: 5 of 7 Total Card 3,370,500 / Total Parcel 34,844,200
APPR 3,370,500 / 34,844,200
USE + IMP 3,370,500 / 34,844,200
USE LAND 3,370,500 / 34,844,200
ASSESSED 3,370,500 / 34,844,200

PROPERTY LOCATION

52 INSTITUTE RD
BURLINGTON, VT 05401

OWNERSHIP

CITY SCHOOL DEPARTMENT
ADMISTRATIVE OFFICES/EED
150 COLCHESTER AV
BURLINGTON, VT 05401-0000

PREVIOUS OWNER

Table with columns: Occ, C, Type, CITY

NARRATIVE DESCRIPTION

This parcel contains 1412709.00000 SF of land mainly classified as Exempt It has 7 building(s) first built in 1968 with a total of 23,870 square feet. There are 7commercial unit(s), 11 Baths, 29 Half Baths.

OTHER ASSESSMENTS

Table with columns: Code, Desc, Amt, Comm Int Amt

PROPERTY FACTORS

Table with columns: Item, Code, Item, Code, %

LAND SECTION

Table with columns: LUC, LUC Desc, Ft, # Units, Depth, U. Type, L. Type, Ft, Base V, Unit Prc, Adi Prc, NBC, Ft, Mod, Inf 1, %, Inf 2, %, Inf 3, %, Apor, Alt LUC, %, Spec I. V., Juris, L. Ft, Assessed, Notes

IN PARCEL APPRAISAL SUMMARY

Table with columns: Use Code, Building Val, Yard Items, Land Size, Land Val, Total Val

PREVIOUS ASSESSMENTS

Table with columns: Tx Yr, Cat, Use, Bld Value, Yard Items, Land Size, Land Val, Total Apor, Assessed, Notes, Date

SALES INFORMATION

Table with columns: Grantor, Legal Ref, Type, Date, Sale Price, TSF, Verif., NAL, Notes

BUILDING PERMITS

Table with columns: Date, Number, Desc, Amount, Closed, Status, Fed. ID, Notes, Last Visit

ACTIVITIES

Table with columns: Date, Result, Bv

LEGAL DESCRIPTION

Table with columns: Lot Size, Total Land, Land Unit Type



User Account table with fields: User Account, 13542, GIS Coord 1, 308543728872.00000000, GIS Coord 1, Insp Date, Print Date / Time, 7/24/2024 1:30 am, Last Date / Time, 6/14/23 3:49 pm, BURLINGTONjturner

USER DEFINED

Table with fields: RAD, OLD PID: 4444SCHOOL, State District, CAD, SPAN: 114-035-13542, Accessory Dwl, PriorID1c, 00, PriorID2c, 00, PriorID3c, 00, Assessor Map

Parcel ID 033-4-019-000

Exterior Information

Table with exterior details: Type 363 - SCHOOLS ELEM, Stry Hght 3 - Three Sty, (Liv) Units 0 Tot 1, Found S - SLAB, Frame C - FireResistAV, P. Wall BV - BRICK VENEER, Sec Wall 0, Roof Str FL - FLAT, Roof Cvr RM - RUBBER MEMB, Color, View AV - AVERAGE, Shape, Bld Name

General Information

Table with general details: Grade A+ - AVERAGE PLUS, Year Blt 1970, Eff Yr, Alt LUC, Juris, Con Mod

Interior Information

Table with interior details: Avg Ht / Fl 9.00, P. Int Wall DW - DRYWALL, Sec Int Wall CB - CON BLOCK 40%, Partition, P. Floor V - VINYL, Sec Floor, Bmt Floors, Sub Floors, Bmt Garage 0, Electric T - TYPICAL, Insulation T - TYPICAL, Int Vs Ext, Heat Fuel G - GAS, Heat HW - HOT WATER, # Heat Sys 2, Heated % 100, AC %, Sol HW %, Ctrl Vac %, Com Wall %, Sprink % 5

Special Features / Yard Items

Table with special features and yard items: Code GRNG, Desc GREENHS GLAS, A D, Y/S Y, Qty 1, Size 288.00, Qual C, Con AV, Year 1970, Unit Prc 56.61, D/S T, Depr % 70%, LUC, Ft. 1, NBC Ft. 1.44, Juris Ft. 1, Appr Val 6,800, Assessed 6,800. Includes Building Totals and Parcel Totals rows.

Comments

BURLINGTON HIGH SCHOOL
E BUILDING

Sketch

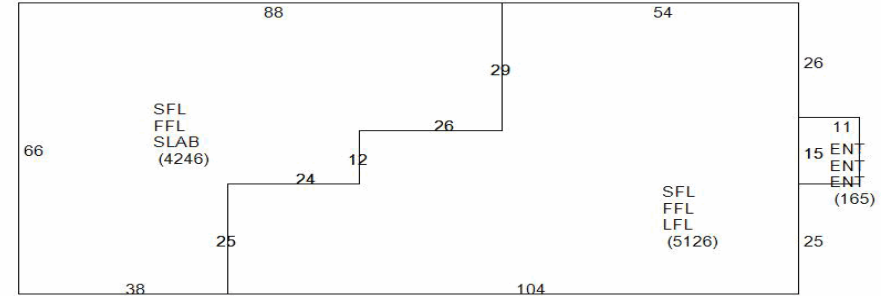

Condo Information

Table with condo details: Location, Tot Units, Floor, % Own, Name

Bath Features

Table with bath features: Full Bath 0 Rtnq, Add Full 0 Rtnq, 3/4 Bath 0 Rtnq, Add. 3/4 0 Rtnq, 1/2 Bath 3 Rtnq, Add. 1/2 0 Rtnq, Other Fix 27 Rtnq

Other Features

Table with other features: Kitchens 0 Rtnq, Add Kit. 0 Rtnq, Fireplaces 0 Rtnq, WS Flues 0 Rtnq

Depreciation

Table with depreciation: Phys Con AV 30, Functional, Economic, Special, Override, Total 30%

Comparable Sales

Table with comparable sales: Rtnq, Parcel ID, Type, Sale Date, Price, Avg Rtnq, Ind Val

Res Breakdown

Table with res breakdown: Floor, No. Unit, Rooms, Bdrms, Bld Total, Prcl Total

Calc Ladder

Table with calc ladder: Base Rate 104.60, Depr 1,441,582, Size Adj 1.00000, Depr'd Total 3,363,690, Con Adj 1.10237, Juris Ft. 1.0000, Adj Prc \$115.31, Spec. Features \$0, Grade Ft. 1.07000, Lump Sum, Other Feat \$38,503, Final Total \$3,363,700, NBH Mod 1.0000, Override Val, NBC Infl 1.6700, Assmnt Ft. 1.0000, LUC Ft. 1.0000, Assessed Val \$3,363,700, Adj Tot (RCN) 4,805,272, Total \$/SF \$140.92, Depr % 30%, Undepr \$/SF 123.38170

Remodeling

Table with remodeling: Exterior, Interior, Add, Kitchen, Bath, Plumb, Electric, Heating, General

Mobile Home

Table with mobile home details: Make, Model, Serial, Year, Color

Sub Areas

Table with sub areas: Code, Desc, Net Area, Gross A., F. Area, Sz Adj A., Rate AV, Undepr Val, Building Totals, Parcel Totals

Alt Areas

Table with alt areas: S. Area, Alt Type, % Alt, Tenants, Qual, % U

Image



033 Sheet 4 Lot 019 Unit# 000 Bldg#

033-4-019-000 Parcel ID Building Location 52 INSTITUTE RD

BURLINGTON, VT

Card: 6 of 7 Total Card 5,429,000 / 34,844,200
 APPR 5,429,000 / 34,844,200
 USE + IMP 5,429,000 / 34,844,200
 USE LAND 5,429,000 / 34,844,200
 ASSESSED 5,429,000 / 34,844,200

PROPERTY LOCATION
 52 INSTITUTE RD
 BURLINGTON, VT 05401

IN PARCEL APPRAISAL SUMMARY

Use Code	Building Val	Yard Items	Land Size	Land Val	Total Val
E	5,394,400	34,600	0.00	0	5,429,000
Buildino Total 5,394,400 34,600 0.00 0 5,429,000					
Parcel Total 34,314,300 178,900 1,412,709.00 351,000 34,844,200					
Source 0 - Mkt Adj Cost Tot Val SF/Bld 146.45 Tot Val SF/Prcf 149.83					

LEGAL DESCRIPTION

Lot Size	
Total Land	1,412,709.00
Land Unit Type	SF

OWNERSHIP
 CITY SCHOOL DEPARTMENT
 ADMISTRATIVE OFFICES/EED
 150 COLCHESTER AV
 BURLINGTON, VT 05401-0000

PREVIOUS ASSESSMENTS

Property ID: 3542

Tx Yr	Cat	Use	Bld Value	Yard Items	Land Size	Land Val	Total Aoor	Assessed	Notes	Date
2024	FV	E	34,314,300	178,900	1,412,709	351,000	34,844,200	34,844,200	2024/LDS 06/14/24 11:54:51	06/14/2024
2023	FV	E	34,314,300	178,900	1,412,709	351,000	34,844,200	34,844,200	2023/LDS 07/07/23 9:47:36	07/07/2023
2022	FV	E	34,314,300	178,900	1,412,709	351,000	34,844,200	34,844,200	2022/LDS 08/25/22 10:15:25	08/25/2022
2021	FV	E	34,314,300	178,900	1,412,709	351,000	34,844,200	34,844,200	DS Patriot Support	01/11/2022
2020	FV	E	26,703,500	167,100	1,412,709	5,556,400	32,427,000	32,427,000	post BOA	06/23/2020
2019	FV	E	26,703,500	167,100	1,412,709	5,556,400	32,427,000	32,427,000	9.23.2019	09/23/2019

PREVIOUS OWNER

Occ	C	Type	CITY
-----	---	------	------

NARRATIVE DESCRIPTION
 This parcel contains 1412709.00000 SF of land mainly classified as Exempt It has 7 building(s) first built in 1968 with a total of 37,070 square feet. There are 7commercial unit(s), 11 Baths, 29 Half Baths.

SALES INFORMATION

Grantor	Legal Ref	Type	Date	Sale Price	TSF	Verif.	NAL	Notes

OTHER ASSESSMENTS

Code	Desc	Amt	Comm Int Amt

BUILDING PERMITS

Date	Number	Desc	Amount	Closed	Status	Fed. ID	Notes	Last Visit

ACTIVITIES

Date	Result	Bv

PROPERTY FACTORS

Item Code	Item	Code	%
Util 1	Dis 1 B		.00000
Util 2	Dis 2 SN		.00000
Util 3	Dis 3		
Census	Zone 1		
F. Haz	Zone 2		
Tono	Zone 3		
Street			
Traffic			
Exempt			

LAND SECTION

LUC	LUC Desc	Ft.	# Units	Depth	U. Type	L. Type	Ft.	Base V.	Unit Prc	Adi Prc	NBC	Ft.	Mod.	Inf 1	%	Inf 2	%	Inf 3	%	Aoor	Alt LUC	%	Spec I. V.	Juris	L. Ft.	Assessed	Notes
E	Exempt	1	1,412,709		SF	SITE	1	39	0.25	610	1			Z						351,000			0	1	351,000		
E	Exempt	1	0		SF	SITE	1	39	0	610	1									0			0	1	0		
E	Exempt	1	0		SF	SITE	1	39	0	610	1									0			0	1	0		
E	Exempt	1	0		SF	SITE	1	39	0	610	1									0			0	1	0		
E	Exempt	1	0		SF	SITE	1	39	0	610	1									0			0	1	0		
E	Exempt	1	0		SF	SITE	1	39	0	610	1									0			0	1	0		
Total AC/HA		32.43		Total SF/SM		1,412,709.00		Parcel LUC E - Exempt			P. NBC Desc		NEW NO END		Tot		351,000		Tot		0		Tot		351,000		



User Account
 13542
 GIS Coord 1
 308543728872.00000000
 GIS Coord 1
 Insp Date
 Print Date / Time
 7/24/2024 1:30 am
 Last Date / Time
 6/14/23 3:49 pm
 BURLINGTONjturner

USER DEFINED
 RAD:
 OLD PID:
 4444SCHOOL
 State District:
 CAD:
 SPAN:
 114-035-13542
 Accessory Dwl
 PriorID1c
 00
 PriorID2c
 00
 PriorID3c
 00
 Assessor Map

Parcel ID 033-4-019-000

Exterior Information

Table with exterior details: Type (363 - SCHOOLS ELEM), Stry Hght (3 - Three Sty), (Liv) Units (0 Tot 1), Found (S - SLAB), Frame (C - FireResistAV), P. Wall (BV - BRICK VENEER), Sec Wall (0), Roof Str (FL - FLAT), Roof Cvr (RM - RUBBER MEMB), Color, View (AV - AVERAGE), Shape, Bld Name.

General Information

Table with general details: Grade (A+ - AVERAGE PLUS), Year Blt (1971), Eff Yr, Alt LUC, Juris, Con Mod.

Interior Information

Table with interior details: Avg Ht / Ft (10.00), P. Int Wall (DW - DRYWALL), Sec Int Wall (CB - CON BLOCK 45%), Partition, P. Floor (V - VINYL), Sec Floor (CON - CONCRETE 30%), Bmt Floors, Sub Floors, Bmt Garage (0), Electric (T - TYPICAL), Insulation (T - TYPICAL), Int Vs Ext, Heat Fuel (G - GAS), Heat (HW - HOT WATER), # Heat Sys (2), Heated % (100), AC %, Sol HW %, Ctrl Vac %, Com Wall %, Sprink %.

Special Features / Yard Items

Table with special features and yard items: Columns include Code, Desc, A, Y/S, Qty, Size, Qual, Con, Year, Unit Prc, D/S, Depr %, LUC, Ft, NBC, Ft, Juris, Ft, Appr Val, Assessed. Includes rows for ELVP, ELEV.PASS., and summary rows for Building and Parcel Totals.

Disclaimer: This Information is believed to be correct but is subject to change and is not quarante

Condo Information

Table with condo details: Location, Tot Units, Floor, % Own, Name.

Bath Features

Table with bath features: Full Bath (3 Rtnq), Add Full (0 Rtnq), 3/4 Bath (0 Rtnq), Add. 3/4 (0 Rtnq), 1/2 Bath (5 Rtnq), Add. 1/2 (0 Rtnq), Other Fix (41 Rtnq).

Other Features

Table with other features: Kitchens (0 Rtnq), Add Kit. (0 Rtnq), Fireplaces (0 Rtnq), WS Flues (0 Rtnq).

Depreciation

Table with depreciation: Phys Con (AV 30), Functional, Economic, Special, Override, Total (30%).

Comparable Sales

Table with comparable sales: Columns include Rtnq, Parcel ID, Type, Sale Date, Price, Avg Rtnq, Ind Val.

Comments

BURLINGTON HIGH SCHOOL
F BUILDING

Res Breakdown

Table with res breakdown: Columns include Floor, No. Unit, Rooms, Bdrms, Bld Total, Prcl Total.

Calc Ladder

Table with calc ladder: Base Rate (104.60), Depr (2,311,868), Size Adj (1.00000), Depr'd Total (5,394,360), Con Adj (1.11050), Juris Ft. (1.0000), Adj Prc (\$116.16), Spec. Features (\$0), Grade Ft. (1.07000), Lump Sum, Other Feat (\$64,200), Final Total (\$5,394,400), NBH Mod (1.0000), Override Val, NBC Infl (1.6700), Assmnt Ft. (1.0000), LUC Ft. (1.0000), Assessed Val (\$5,394,400), Adj Tot (RCN) (7,706,228), Total \$/SF (\$145.52), Depr % (30%), Undepr \$/SF (124.29120).

Sub Areas

Table with sub areas: Columns include Code, Desc, Net Area, Gross A., F. Area, Sz Adj A., Rate AV, Undepr Val, Building Totals, Parcel Totals.

Sketch

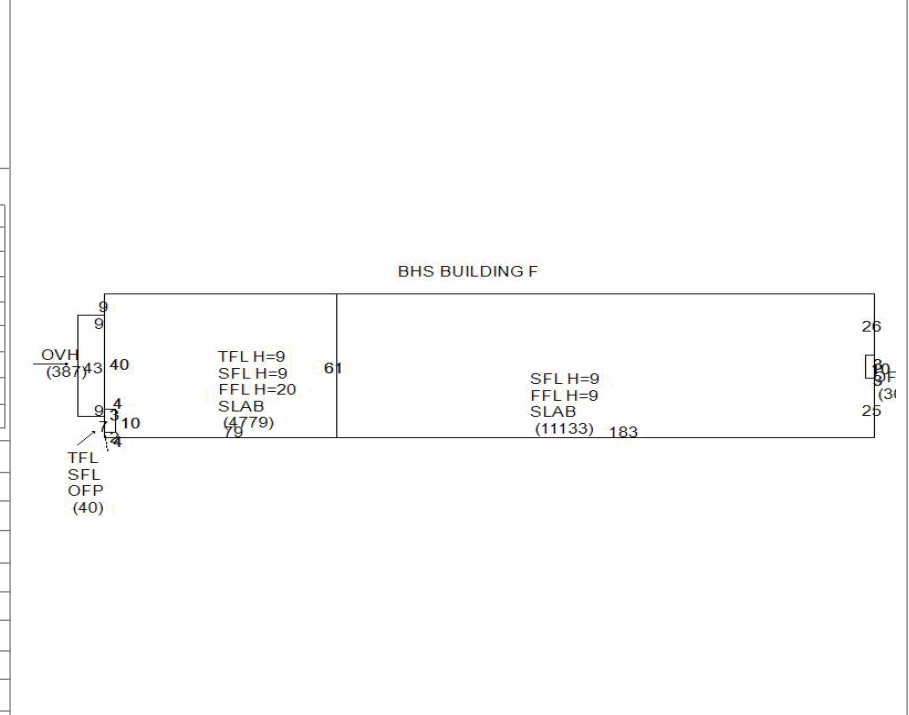

Mobile Home

Table with mobile home details: Make, Model, Serial, Year, Color.

Alt Areas

Table with alt areas: Columns include S. Area, Alt Type, % Alt, Tenants, Qual, % U.

Image



Property: 3542 | Bld: 3618 | Seq: 6 | Year: | Data As Of Date: 07/01/2024 | User: sa | DB: Assess50Burlington

033 Sheet 4 Lot 019 Unit# 000 Bldg#

033-4-019-000 Parcel ID Building Location 52 INSTITUTE RD

BURLINGTON, VT

Card: 7 of 7 Total Card 62,700 / Total Parcel 34,844,200

PROPERTY LOCATION

52 INSTITUTE RD BURLINGTON, VT 05401

OWNERSHIP

CITY SCHOOL DEPARTMENT ADMISTRATIVE OFFICES/EED 150 COLCHESTER AV BURLINGTON, VT 05401-0000

PREVIOUS OWNER

Table with columns: Occ, C, Type, CITY

NARRATIVE DESCRIPTION

This parcel contains 1412709.00000 SF of land mainly classified as Exempt It has 7 building(s) first built in 1968 with a total of 936 square feet. There are 7commercial unit(s), 11 Baths, 29 Half Baths.

OTHER ASSESSMENTS

Table with columns: Code, Desc, Amt, Comm Int Amt

PROPERTY FACTORS

Table with columns: Item, Code, Item, Code, %

LAND SECTION

Large table with columns: LUC, LUC Desc, Ft, # Units, Depth, U. Type, L. Type, Ft, Base V, Unit Prc, Adi Prc, NBC, Ft, Mod, Inf 1, %, Inf 2, %, Inf 3, %, Apor, Alt LUC, %, Spec I. V, Juris, L. Ft, Assessed, Notes

IN PROCESS APPRAISAL SUMMARY

Table with columns: Use Code, Building Val, Yard Items, Land Size, Land Val, Total Val

PREVIOUS ASSESSMENTS

Table with columns: Tx Yr, Cat, Use, Bld Value, Yard Items, Land Size, Land Val, Total Apor, Assessed, Notes, Date

SALES INFORMATION

Table with columns: Grantor, Legal Ref, Type, Date, Sale Price, TSF, Verif, NAL, Notes

BUILDING PERMITS

Table with columns: Date, Number, Desc, Amount, Closed, Status, Fed. ID, Notes, Last Visit

ACTIVITIES

Table with columns: Date, Result, Bv

LEGAL DESCRIPTION

Table with columns: Lot Size, Total Land, Land Unit Type

Property ID: 3542



User Account table with fields: User Account, 13542, GIS Coord 1, 308543728872.00000000, GIS Coord 1, Insp Date, Print Date / Time, 7/24/2024 1:30 am, Last Date / Time, 6/14/23 3:49 pm, BURLINGTON\jturner

USER DEFINED table with fields: RAD, OLD PID: 4444SCHOOL, State District, CAD, SPAN: 114-035-13542, Accessory Dwl, PriorID1c 00, PriorID2c 00, PriorID3c 00, Assessor Map

Parcel ID 033-4-019-000

Exterior Information

Table with exterior details: Type (441 - SMALL SHOP), Stry Hght (1 - One Sty), (Liv) Units (0), Found (S - SLAB), Frame (C - FireResistAV), P. Wall (BV - BRICK VENEER), Sec Wall (MT - STEEL/MET), Roof Str (S - SHED), Roof Cvr (MT - METAL), Color, View (AV - AVERAGE), Shape, Bld Name.

General Information

Table with general details: Grade (A - AVERAGE), Year Blt (1988), Alt LUC, Juris, Con Mod.

Interior Information

Table with interior details: Avg Ht / Fl (16.00), P. Int Wall (CB - CON BLOCK), Sec Int Wall, Partition, P. Floor (CON - CONCRETE), Sec Floor, Bmt Floors, Sub Floors, Bmt Garage (0), Electric (T - TYPICAL), Insulation (T - TYPICAL), Int Vs Ext, Heat Fuel (G - GAS), Heat (HW - HOT WATER), # Heat Sys (3), Heated % (100), Sol HW %, Com Wall %.

Special Features / Yard Items

Table for special features and yard items with columns: Code, Desc, A, Y/S, Qty, Size, Qual, Con, Year, Unit Prc, D/S, Depr %, LUC, Ft, NBC, Ft, Juris, Ft, Appr Val, Assessed.

Disclaimer: This Information is believed to be correct but is subject to change and is not guarantee

Condo Information

Table with condo details: Location, Tot Units, Floor, % Own, Name.

Bath Features

Table with bath features: Full Bath, Add Full, 3/4 Bath, Add. 3/4, 1/2 Bath, Add. 1/2, Other Fix, each with Rtng.

Other Features

Table with other features: Kitchens, Add Kit., Fireplaces, WS Flues, each with Rtng.

Depreciation

Table with depreciation details: Phys Con (AV), Functional, Economic, Special, Override, Total (24.8%).

Comparable Sales

Table for comparable sales with columns: Rtnq, Parcel ID, Type, Sale Date, Price, Avg Rtnq, Ind Val.

Comments

BURLINGTON HIGH SCHOOL
G BUILDING BOILER ROOM
PROVIDES HEAT FOR CAMPUS

Res Breakdown

Table with res breakdown: Floor, No. Unit, Rooms, Bdrms, Bld Total, Prcl Total.

Calc Ladder

Table with calc ladder: Base Rate (37.60), Size Adj (1.00000), Con Adj (1.22482), Adj Prc (\$46.05), Grade Ft (1.00000), Other Feat (\$1,000), NBH Mod (1.0000), NBC Infl (1.6700), LUC Ft (1.0000), Adj Tot (83,415), Depr % (24.8%), Total \$/SF (46.05000).

Sub Areas

Table with sub areas: Code, Desc, Net Area, Gross A., F. Area, Sz Adj A., Rate AV, Undepr Val, Building Totals, Parcel Totals.

Sketch

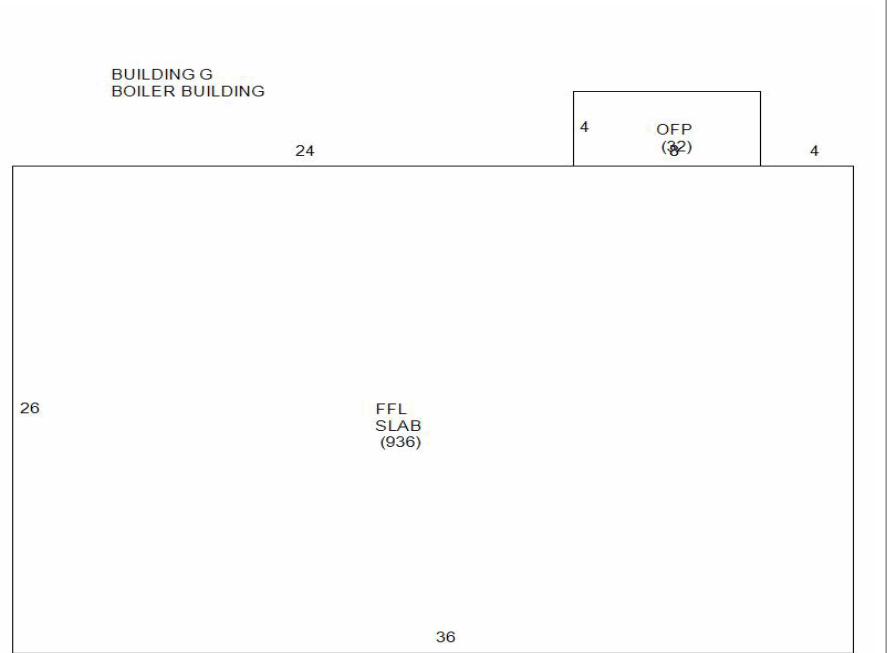

Mobile Home

Table for mobile home details: Make, Model, Serial, Year, Color.

Alt Areas

Table for alternative areas with columns: S. Area, Alt Type, % Alt, Tenants, Qual, % U.

Image



Property: 3542 | Bld: 3619 | Seq: 7 | Year: | Data As Of Date: 07/01/2024 | User: sa | DB: Assess50Burlington